

Inlet Barge

As near as we were able to tell from some of the Martin County Archives, the Inlet Barge was deployed sometime between 1980 and 1986 in the Donaldson Permitted Area. The reason it is called the Inlet Barge is not known, as there are other barges that are closer to the St. Lucie Inlet. It sits upright in about 58 feet of water.

The F.O.S. Dive Team has very little data on the Inlet Barge prior to the Monitoring event of 2004. It is not a very attractive site for divers as it rests in a high silt area. The current data shows this barge to be in very poor condition with extensive collapse and it is partially buried. What is left of the barge is heavily encrusted and has a decent fish population including 2 resident Goliath Grouper.

Florida Oceanographic Society Research Dive Team
Florida Fish & Wildlife Conservation Commission Monitoring Grant

"Artificial Reef Stability Assessment Survey"
Martin County Florida

"Inlet Barge"

Date of Survey: April 24, 2004

Research Divers: Wayne Turner, Bill Scammell, Fran Krawetz, Bob Gilmore,

Reef Material: Steel Barge
Orientation: North and South
Bottom Composition: Sand and Shell
General Condition of Material: Very Poor
Collapse: Most of the North end has collapsed and filled in with sand. Some of the collapse is so severe that the top of the Barge is just a few inches off the bottom.
Scattering: None noticed.
Disintegration: Most of the deck has disintegrated and the support beams are exposed.
Additional Observations: There is not much left of this Barge. Most of the sides are missing but it does allow for some good swim throughs for Marine life. Heavy Benthic encrustation.

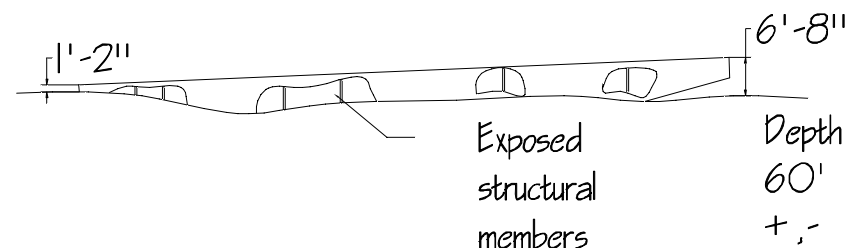

"Inlet Barge"
 Mapped 04-24-04
 Drawn by BS 11-27-04

Exposed structural members from metal deterioration

Depth 60' +/-

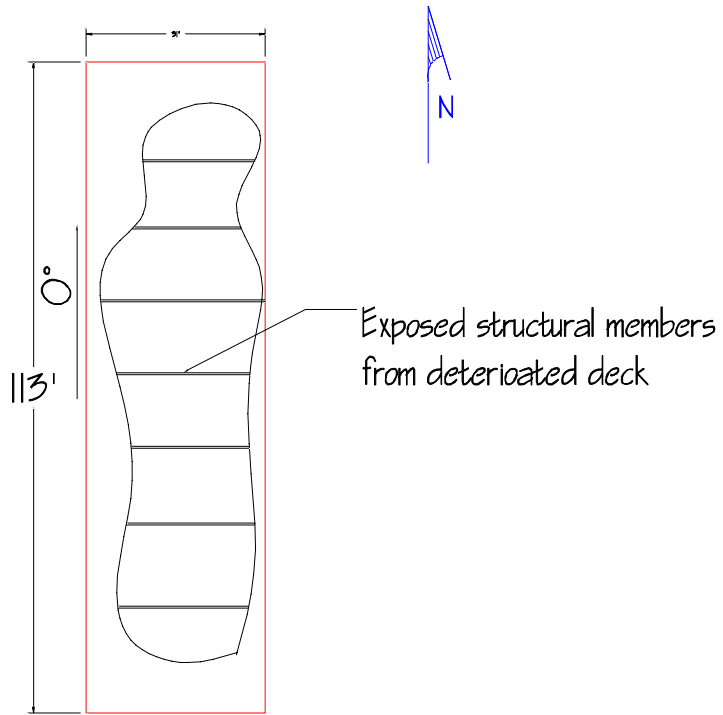

Exposed structural members from deteriorated deck

Inlet Barge

Survey Dates: 24 April and 17 July 2004

Benthic species listed below were identified using both photo interpretation and the roving diver technique. Digital still images of the Inlet Barge were captured on April 24. The site was revisited on July 17, at which time professionally trained divers spent 25 minutes documenting benthic invertebrates and macroalgae. Organisms captured in the digital still images in April were quickly identified to the lowest recognizable taxon. In July, organisms were recorded on an underwater slate and, when necessary, verified at the surface using reference guides. Some of the most relevant guides for Martin County's reefs include: 1) Littler and Littler's Caribbean Reef Plants: An Identification Guide to the Reef Plants of the Caribbean, Bahamas, Florida and Gulf of Mexico, 2) Hendler, Miller, Pawson and Kier's Echinoderms of Florida and the Caribbean: Sea Stars, Sea Urchins, and Allies, and 3) Paul Humann's Reef Creature Identification: Florida Caribbean and Bahamas. Documented organisms were placed in one of the following abundance classifications for long-term analysis: Single (1), Few (2-10), Many (11-100) or Abundant (>100).

<u>Benthic Species Identified</u>	<u>Abundance</u>	<u>Comments</u>
Green Algae		
<i>Codium decorticatum</i>	Few	
<i>Codium</i> sp.	Many	
<i>Bryopsis</i> sp.	Single	
Brown Algae		
<i>Spatoglossum</i> sp.	Few	
Red Algae		
<i>Amphiroa</i> sp.	Abundant	
<i>Asparagopsis</i> sp.	Many	Scarlet red tufts of algae approximately 2 cm tall.
<i>Rhodomenia</i> sp.	Abundant	
Sponges		
<i>Anthosigmella varians</i>	Few	
Orange sponge	Abundant	
Black ball sponge (<i>Ircinia strobilina</i>)	Few	
Worms		
Feather dusters	Many	
Gastropods		
Sea hare (<i>Aplysina morio</i>)	Many	Near a site with hundreds of mating chains.
Cnidarians		
<i>Leptogorgia</i> sp.	Few	Bright yellow sea whip (maybe <i>L. virgulata</i>).
Regal sea fan (<i>Leptogorgia hebes</i>)	Few	
White telesto (<i>Carijoa riisei</i>)	Few	
Branching hydroids	Abundant	
Feather hydroids	Abundant	
Anemone	Many	
Tunicates		
Compound tunicates (<i>Eudistoma</i> spp.)	Many	

* Note that an adult loggerhead sea turtle (*Caretta caretta*) was observed resting under a ledge in April 2004.

